

7" & 9" INDUSTRIAL THERMOMETERS

ADJUSTABLE ANGLE

Miljoco industrial thermometers are designed for commercial construction & industrial applications such as piping & air ducts. This instrument represents the accepted worldwide engineering standard for industrial thermometers with die cast aluminum case construction for rugged durability. The non-toxic, green organic spirit-filled tube provides an accurate and quick response while maintaining environmental safety.

GENERAL SPECIFICATIONS

CASE: Precision Die Cast Aluminum for maximum durability in the most abusive installations. Furnished with a anti-scratch, dark green, hard powder coat finish.

LENS: Standard clear shatter proof polycarbonate, or optional double strength glass.

SCALE: Aluminum with white finish and black markings. The scale is V-shaped for optimum readability.

TUBE: Furnished standard with non-toxic, green organic spirit-filled glass tube. The tube is shock mounted to reduce separation during shipment and use. The bore over the spirit column is filled with nitrogen to prevent oxidation.

ADJUSTABLE FITTING: Finished to match the case and provides 180° of vertical plane, and 360° in the horizontal plane, which is locked in place with a screw.

CONNECTION: A brass swivel or commonly used 1-1/8"-18 thread jam nut is used to secure a union hub or separate socket over the sensory bulb.

STEM & BULB CHAMBER: Die Cast Aluminum, tapered to fit standard industrial sockets. The bore of the stem chamber is filled with graphite, encompassing the thermometer bulb, to provide maximum speed of temperature response.

ACCURACY: + 1 Scale Division

BASIC* CATALOG NO.	SCALE SIZE	STEM LENGTH	DIMENSIONS (IN.)			
			A	B	C	U
SX935	9"	3-1/2"	10.25	6.0	5.25	2.5
SX960	9"	6"	10.25	8.5	7.75	5.0
SX735	7"	3-1/2"	8.25	6.0	5.25	2.5
SX760	7"	6"	8.25	8.5	7.75	5.0

MILJOCO
CORPORATION

14335 E. NINE MILE RD., WARREN, MI 48089 www.miljoco.com PHONE 586 777-4280 FAX 586 777-7891

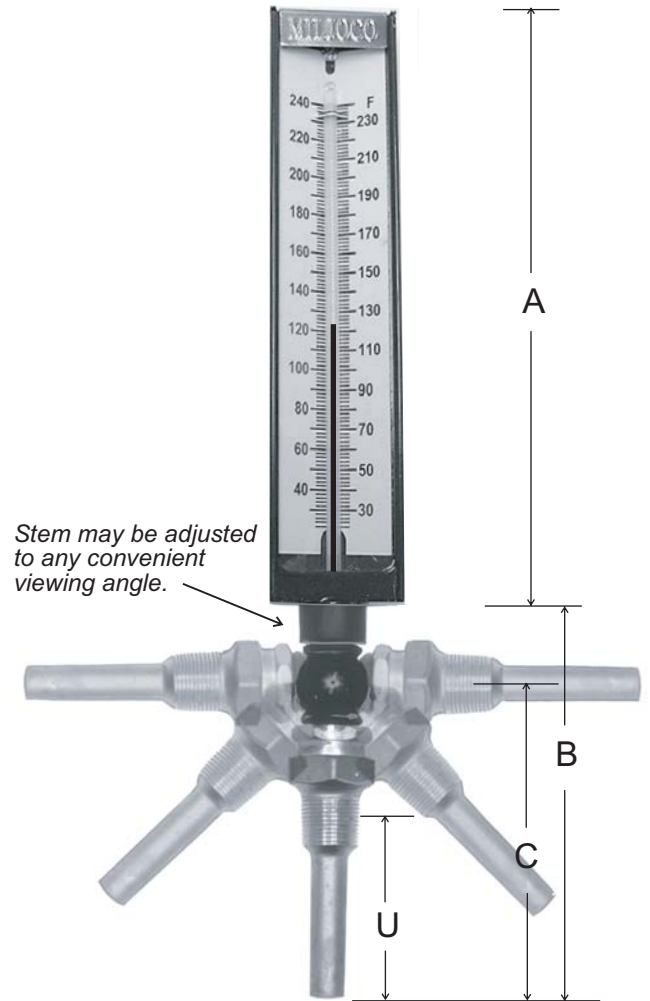

* Add Range number to Basic catalog number
i.e. SX935-50, see pages 5 & 6.

INDUSTRIAL THERMOMETERS

CATALOG NUMBERS FOR STANDARD RANGES

RANGE NO.	RANGE	MAJOR GRADUATIONS	MINOR GRADUATIONS
30	-40 to 110°F	10°	2°
35	0 to 120°F	5°	1°
75	0 to 160°F	10°	2°
77	30 to 180°F	10°	2°
50	30 to 240°F	10°	2°
60	30 to 300°F	10°	2°
31	-40 to 110°F & -40 to 40°C	10° & 5°	2° & 1°
36	0 to 120°F & -10 to 50°C	5°	1°
51	30 to 240°F & 0 to 115°C	10° & 5°	2° & 1°
61	30 to 300°F & 0 to 150°C	10° & 5°	2° & 1°

Add the range number from this scale to the catalog number from the opposite page to complete the full catalog number for ordering, i.e.: SX93550-W35B, which would be a 9" adjustable angle industrial thermometer with a 3-1/2" stem and a 3-1/2" brass socket, with a range of 30 to 240 F. To order a thermometer without a socket - specify i.e. SX93550. * Most ranges are stocked in 9" scale size thermometers.

COMPANION SEPARABLE SOCKETS



6" SOCKET



6" SOCKET w/EXT. NECK



3-1/2" SOCKET

COMPANION 3/4" NPT SEPARABLE SOCKET				
STEM LENGTH	IMMERSION LENGTH	EXT. NECK LENGTH	CATALOG NUMBERS	
			BRASS	316 S.S.
3-1/2"	2-1/2"	NONE	W35B	W35316
3-1/2"	1-1/2"	1"	W351B	N/A
6"	5"	NONE	W60B	W60316
6"	2-1/2"	2-1/2"	W62B	W62316



3-1/2" SOCKET w/EXT. NECK

Longer stem lengths are available as options - consult factory for price and availability. Cap & chain can be supplied for test well service.

MILJOCO
CORPORATION

14335 E. NINE MILE RD., WARREN, MI 48089 www.miljoco.com PHONE 586 777-4280 FAX 586 777-7891

INDUSTRIAL THERMOMETERS

SCALES FOR STANDARD RANGES

The ranges listed below are normally available from stock in the 9" scale size with 3-1/2" stem length. Other ranges are also available on special order.



RANGE 30

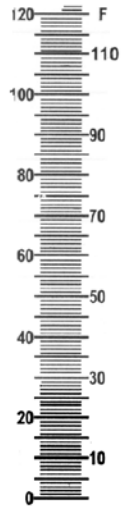

RANGE 35

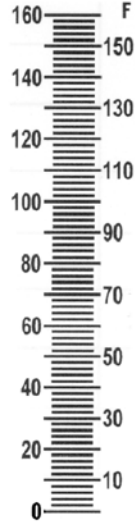

RANGE 75

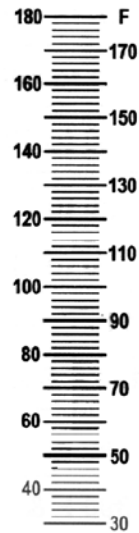

RANGE 77

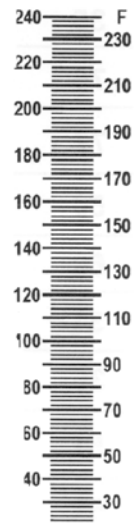

RANGE 50



RANGE 60

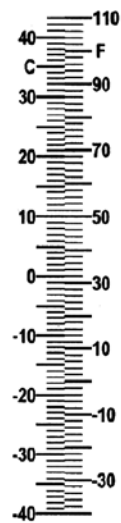

RANGE 31

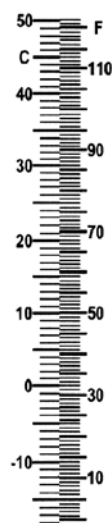

RANGE 36

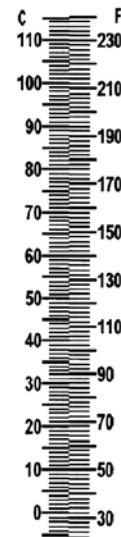

RANGE 51



RANGE 61

MILJOCO
CORPORATION

14335 E. NINE MILE RD., WARREN, MI 48089 www.miljoco.com PHONE 586 777-4280 FAX 586 777-7891